



PAR19X12L

19x 12W LED RGBWAU Parcan with IR Remote

USER MANUAL



For your safety, please read this user manual carefully before use.

Event Lighting reserves the right to revise the manual at any time. Information and specifications within this manual are subject to change without notice. Event Lighting assumes no liability or responsibility for any errors or omissions. Please consult your local Kookaburra Account Manager for any clarification or information regarding this item.

Version 1.1

Safety Instructions

Warning

- Do not open this device, there are no user serviceable parts inside. Risk of electric shock.
- Do not look directly at the light source from close range.
- Avoid contact with the unit during operation, as the housing may become hot. Allow the fixture to cool for at least 15 minutes after turning off before touching.
- Install this device in a location with adequate ventilation, at least 50cm from adjacent surfaces.
- Do not operate this device, or connect this device to power, within 50cm of any flammable material.
- Use a safety chain when mounting this device overhead.
- Do not operate this device outdoors where excessive dust, heat, water, or humidity may affect it.
- Do not operate this device if the housing, lenses, or cables appear damaged.
- Do not connect this device to a dimmer or rheostat.
- Do not operate this device at temperatures higher than 40°C (104°F).
- **Only** connect this device to a grounded and protected circuit.
- **Only** use the hanging bracket to carry this device.
- Stop using this device immediately if a serious operating problem becomes apparent.

Coin/Button Cell Battery Safety Information



This product includes an IR remote that contains a coin/button cell battery. If the battery is swallowed, it can cause severe internal burns and, in extreme cases, can lead to death. Keep batteries away from children.

Product Installation

PAR19X12L can be mounted in many orientations, provided each individual device is secured by the use of the correct mounting bracket. Use a safety chain when mounting PAR19X12L overhead.

Dimensions

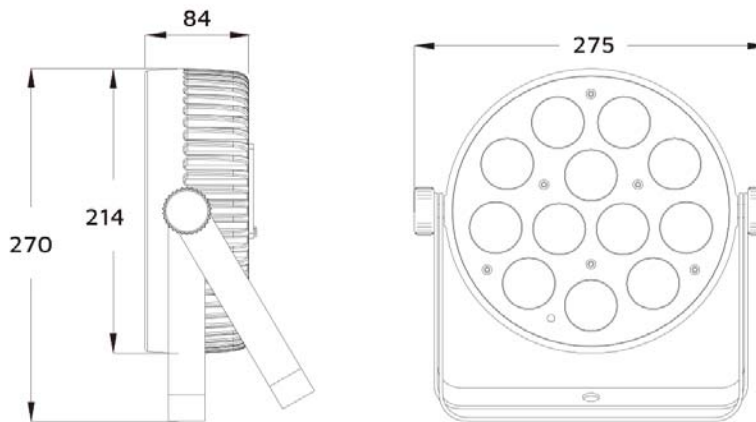

Lux Chart

Lux	@40°				
	1m	2m	3m	4m	5m
	Ø0.73	Ø1.46	Ø2.18	Ø2.91	Ø3.64
R	2,850	650	290	162	107
G	4,310	1,112	495	286	180
B	6,290	1,340	670	385	250
W	4,850	1,278	598	349	230
A	705	170	82	43	32
UV	2,460	695	325	186	124
Full	12,730	3,310	1,436	845	545

Control Board Operation

Menu Map

Addr	→	d 1	-	05 12	Select DMX address
CHNL	→	CH-1	or	CH-2	Select DMX channel mode (CH-1: 6ch / CH-2: 11ch)
SP--	→	SP 0	-	SP99	Set program speed
Pr--	→	Pr 1	-	Pr 13	Select built-in program
SOUND	→	SoU	Select sound active mode		
CoLo	→	C 1	-	C 15	Select static colour mode (See static colour mode chart below)
StroB	→	S. 00	-	S. 20	Set strobe speed (Hz)
rL--	→	r 0	-	r255	Set red colour intensity
GL--	→	G 0	-	G255	Set green colour intensity
BL--	→	b 0	-	b255	Set blue colour intensity
UL--	→	U 0	-	U255	Set white colour intensity
YL--	→	Y 0	-	Y255	Set amber colour intensity
PL--	→	P 0	-	P255	Set UV colour intensity
nodE	→	nod0	-	nod4	Set dimmer speed (nod0: fastest / nod4: slowest)
LEd	→	off	or	on	Toggle LED display on / off
	→	t048	Long press "Enter" button to show current temperature		
VERn	→	V01	Show current software version		
rSEt	→	no	or	YES	Restore settings to factory default

Static Colour Mode

Value	Function
C1	Red
C2	Green
C3	Red+Green
C4	Blue
C5	Blue+Red+UV
C6	Green+Blue
C7	Red +Green+Blue+Amber+UV
C8	White
C9	Red+White
C10	Green+White
C11	Red+Amber
C12	Blue+White+UV
C13	Red + Blue+White+UV
C14	Red + Blue+White
C15	Red+Green+Blue+White+Amber+UV

DMX Chart

6 Channel Mode

Channel	Value	Function
1	000-255	Red: 0% ~ 100%
2	000-255	Green: 0% ~ 100%
3	000-255	Blue: 0% ~ 100%
4	000-255	White: 0% ~ 100%
5	000-255	Amber: 0% ~ 100%
6	000-255	UV: 0% ~ 100%

11 Channel Mode

Channel	Value	Function	Note
1	000-255	Master Dimmer 0% ~ 100%	
2	000-255	Red: 0% ~ 100%	
3	000-255	Green: 0% ~ 100%	
4	000-255	Blue: 0% ~ 100%	
5	000-255	White: 0% ~ 100%	
6	000-255	Amber: 0% ~ 100%	
7	000-255	UV: 0% ~ 100%	
8	000-011	Strobe OFF	
	012-255	Strobe (slow-fast)	
9	000-009	No Function	
	010-019	Program 1	
	020-029	Program 2	
	030-039	Program 3	
	040-049	Program 4	
	050-059	Program 5	
	060-069	Program 6	
	070-079	Program 7	
	080-089	Program 8	
	090-099	Program 9	
	100-109	Program 10	
	110-119	Program 11	
	120-129	Program 12	
	130-139	Program 13	
140-255	Sound active mode		
10	000-255	Speed of auto programs (slow ~ fast)	Ch9 must be set between 10-139
11	000-255	Colour fade time (jump ~ fade)	Mode must be set to "nod0"

IR Remote

In order to use the IR Remote, PAR19X12L must be in DMX mode without an active DMX connection. If a DMX signal is received, PAR19X12L will prioritise the DMX signal and ignore the IR Remote.

Use **On/Off** to turn PAR19X12L on or off. The current IR settings will be saved automatically when PAR19X12L is powered off and reloaded when it is turned on again. To reset to the factory default Blackout mode, long press **Off**.

Press **R/G/B/W/A/U** to light up the LEDs in red, green, blue, white, amber or UV respectively. Press a number **0-9** in the orange shaded area to select a pre-set colour.

Press **+** to increase the intensity of the selected colour and **-** to decrease the intensity of the selected colour.

Press **Auto/Sound/Strobe** to switch on or off Auto mode, Sound Active mode and Strobe mode, respectively.

Press **Blackout** to clear all the remote settings and blackout PAR19X12L.



Technical Specifications

Photometrics

- Light Source: 19x 12W RGBWAWU 6-in-1 LEDs
- Beam Angle: 40°
- PWM: 20,000 Hz
- LED Lifespan: 50,000 hours

Effects

- Dimming: 0~100%
- Strobe: 1 - 20 Hz

Power

- Input Voltage: 100~240V AC, 50/60Hz
- Power Consumption: 100W
- Connection: powerCON in/out

Control

- Protocol: DMX512
- DMX channels: 6/11
- Interface: 3-pin DMX in/out
- Built-in Programming: Yes
- Display: 4-button and 4-digit LED control panel
- Operation Modes: DMX, manual, auto, sound active, IR remote, master/slave

Housing

- Materials: Die cast aluminium, matte black finish
- Cooling: Fanless Cooling
- Net weight: 2.8 kg
- Overall Size: 275x270x84 mm

Warranty

Please contact your local Kookaburra Account Manager.